

haubold®

RNC50M

Onderdelen tekeningen

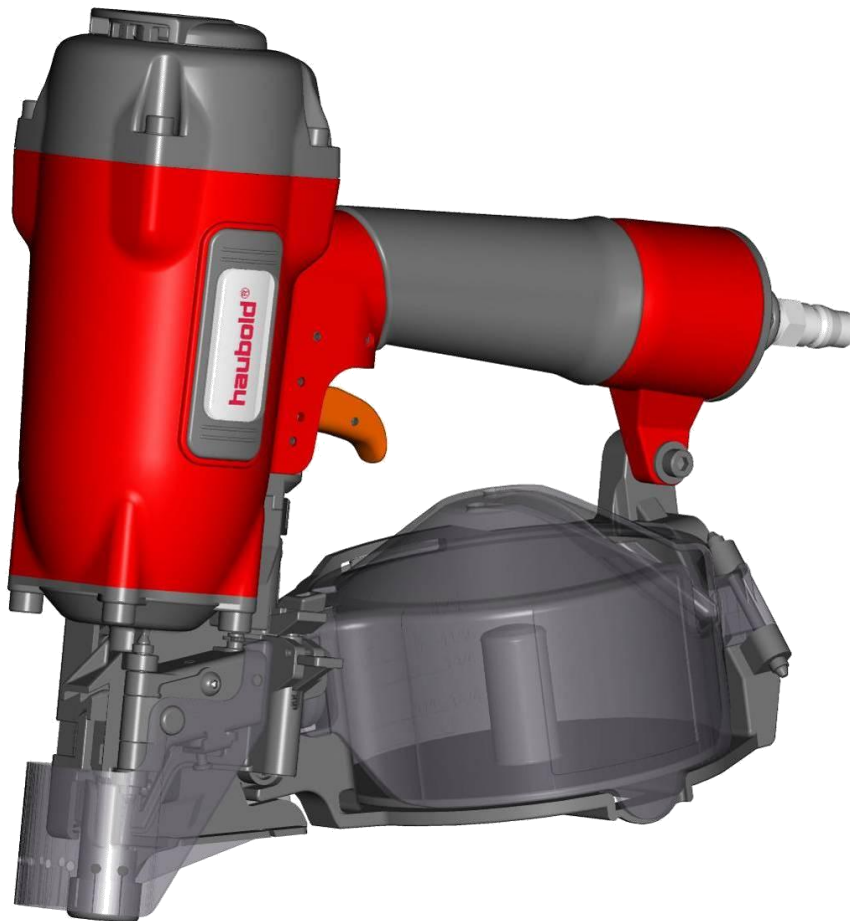

D: Bedienungsanleitung
NL: Gebruiksaanwijzing
F: Manuel d'utilisation
E: Instrucciones de uso
P: Manual de Instruções
I: Istruzioni d'uso
DK: Brugsanvisning
S: Bruksanvisning

N: Bruksanvisning
FIN: Käyttöohjeet
EE: Kasutusjuhend
PL: Instrukcja obsługi
CZ: Návod k obsluze
H: Használati utasítás
SLO: Navodila za uporabo
HR: Upute za rukovanje

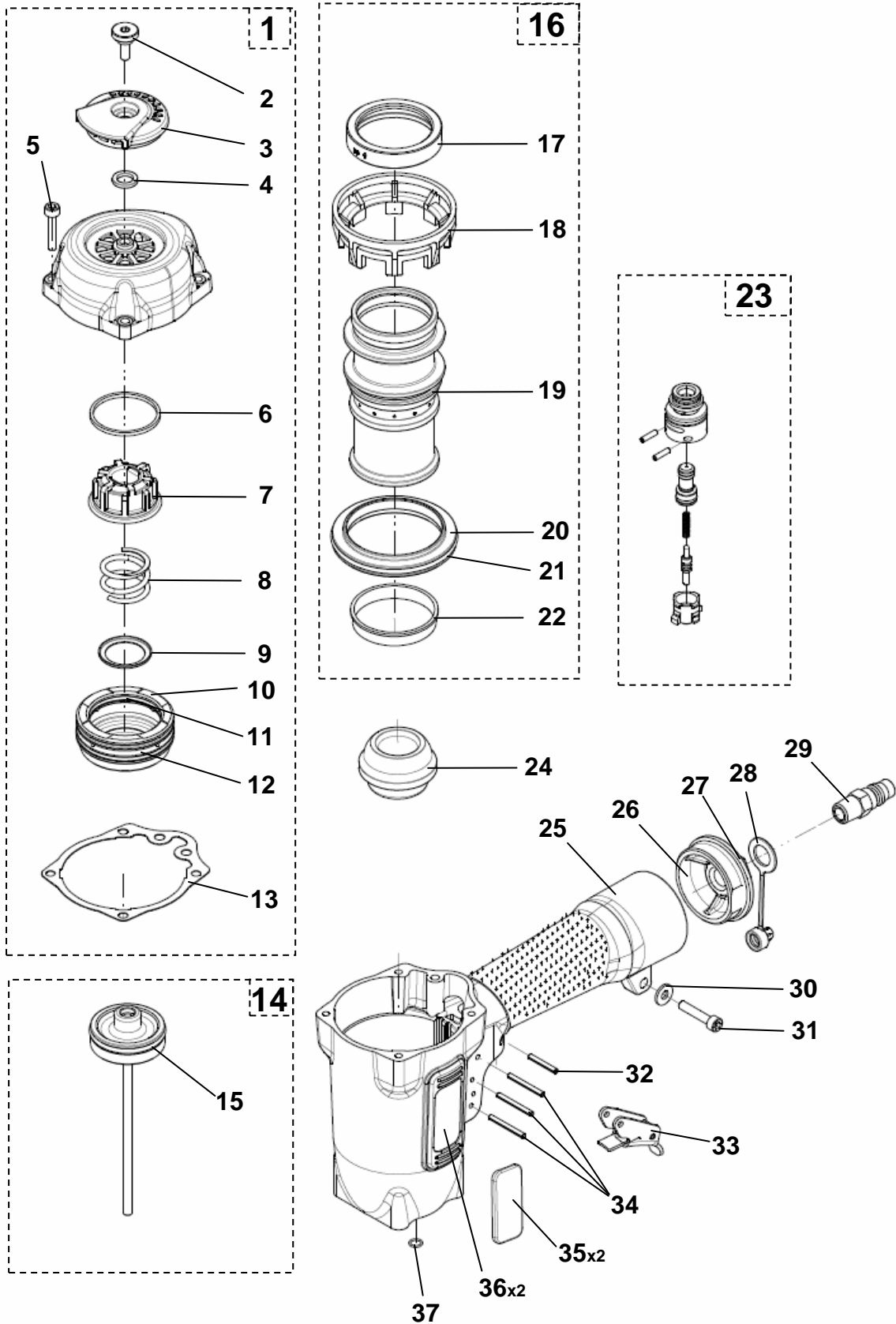

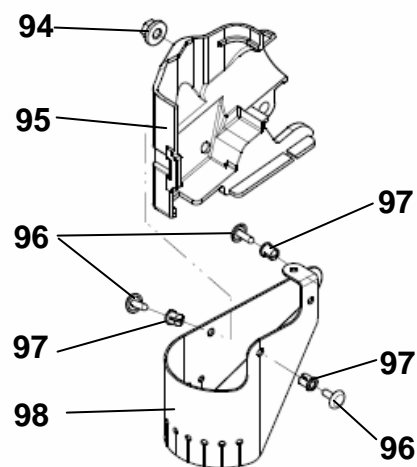
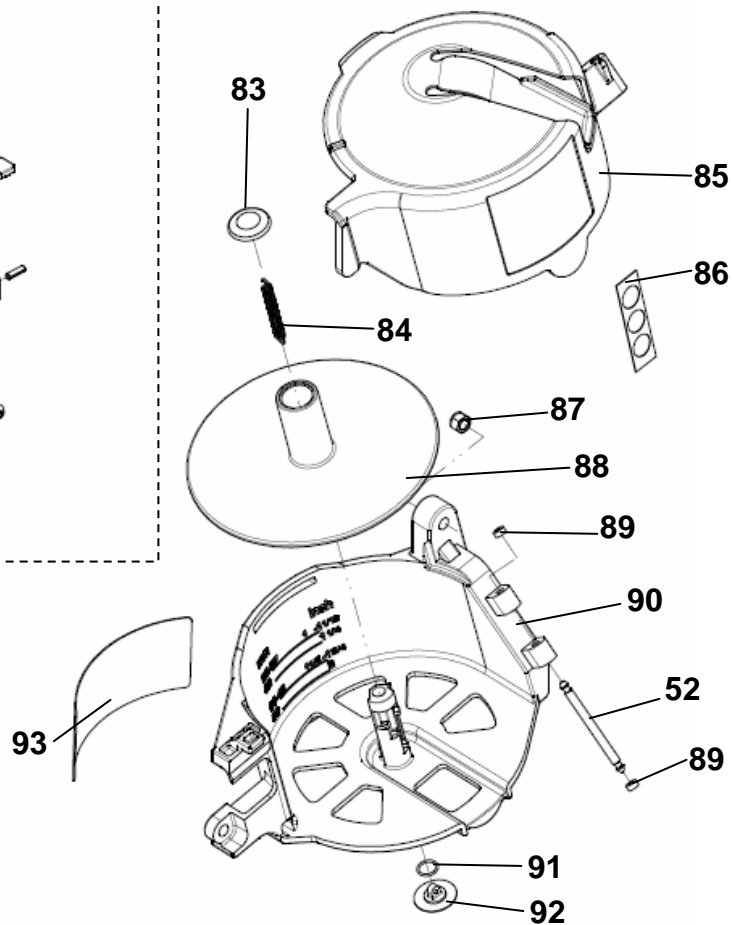
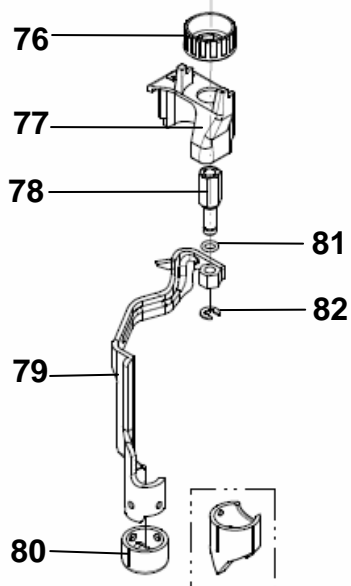
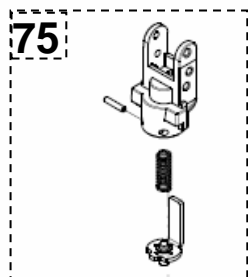
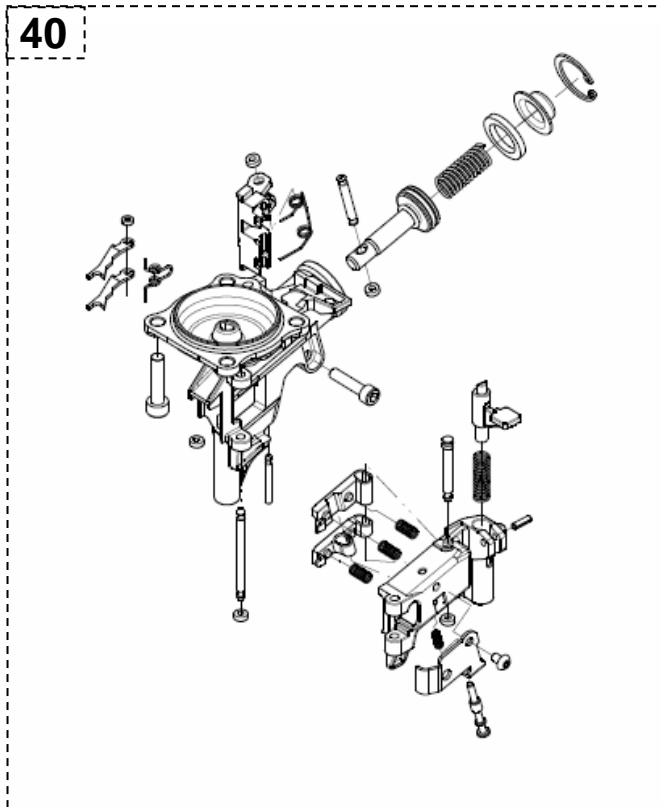

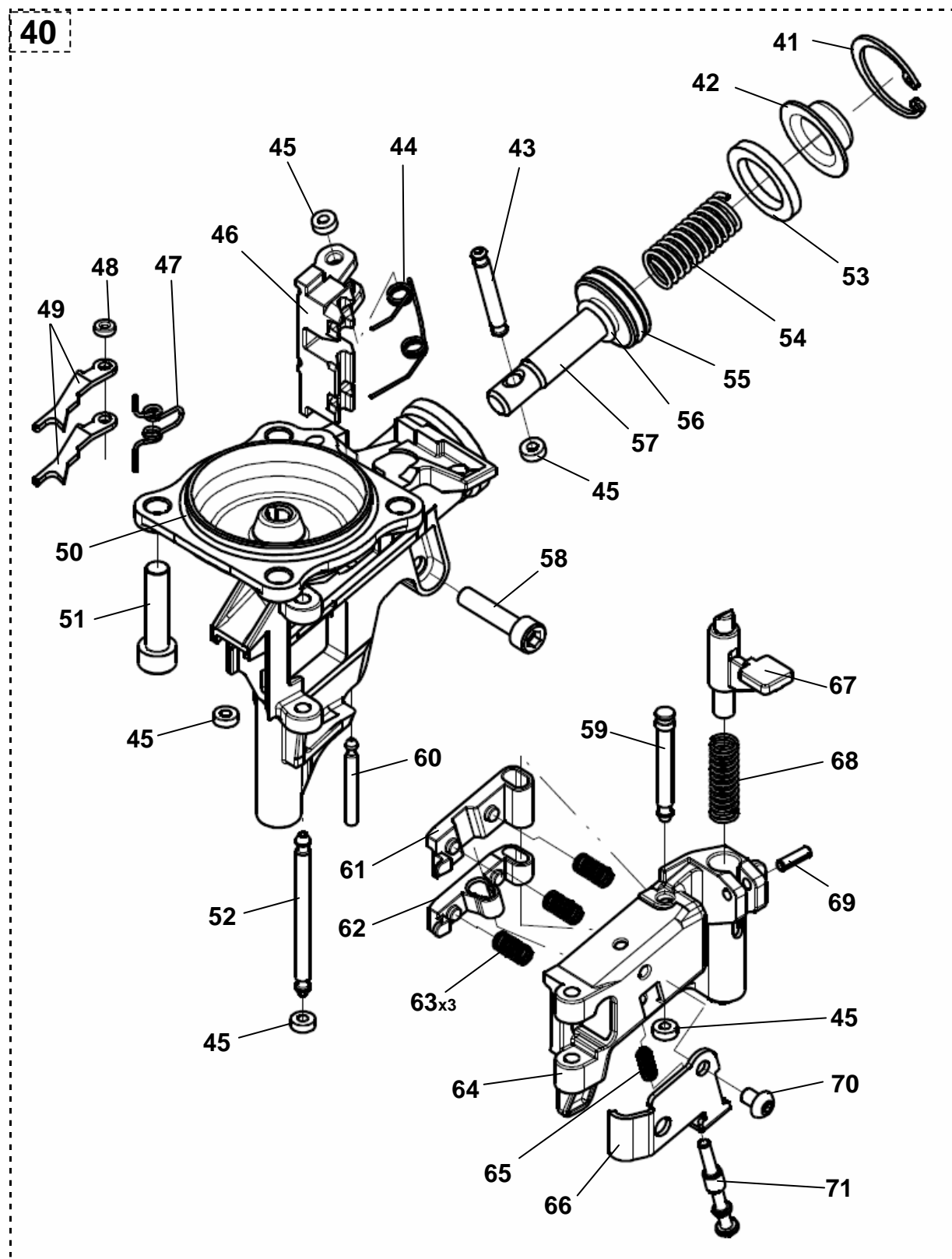

No.	Code	Name	No.	Code	Name
1	613733	CAP ASM.	50	613686	O-RING
2	613205	DEFLECTOR BOLT	51	613708	SCREW
3	613301	DEFLECTOR	52	613700	DOOR SHAFT PIN
4	613207	RUBBER PAD	53	613691	FEED BUMPER
5	613682	BOLT + WASHER	54	613690	SPRING
6	613683	WASHER SEAL	55	613688	O-RING
7	613789	SEAL	56	613254	O-RING
8	613684	SPRING	57	613687	FEED PISTON
9	613788	WASHER	58	613707	SCREW
10	613785	HD.VALVE PISTON	59	613706	PIN-NAIL STOP
11	613786	O - RING	60	613699	PIN-NAIL STOP
12	613787	O - RING	61	613696	NAIL STOP
13	613673	PACKING	62	613705	SPACER
14	613734	PISTON ASM.	63	613263	STOPPER FINGER SPRING
15	613674	O - RING	64	613701	DOOR
16	613735	CYLINDER ASM.	65	613729	SPRING
17	613672	COLLAR	66	613730	NAIL GUIDE COVER
18	613794	CYLINDER PRESS RING	67	613703	DOOR LATCH
19	613675	O - RING	68	613702	LATCH SPRING
20	613792	CYLINDER SPACER	69	613704	SPRING PIN
21	613676	O - RING	70	613725	SCREW
22	613793	CYLINDER RING	71	613731	ROD
23	613736	TRIGGER VALVE ASM.	75	613737	SAFETY ASM.
24	613677	BUMPER	76	613711	ADJUST AXIE
25	613680	GUN BODY UNIT	77	613712	COVER-SAFETY
26	613681	END CAP	78	613713	ADJUST ROD
27	613244	O - RING	79	613800	SAFETY A UNIT
28	571563	DUSTY COVER	80	613801	PROTECTIVE CASING A
29	574360	AIR PLUG	81	613247	O-RING
30	613724	WASHER	82	613715	E - RING
31	613723	SCREW	83	613718	SPRING BASE A
32	613238	SPRING PIN	84	613719	SPRING
33	613679	TRIGGER UNIT (contact)	85	613717	MAGAZINE COVER
	574499	TRIGGER UNIT (sequential)	86	613099	WARNING LABEL
34	613237	SPRING PIN	87	574390	LOCK NUT
35	574497	LOGO LABEL	88	613720	SPACER
36	574496	LABEL HOLDER	89	613722	SHAFT RING
37	613689	O-RING	90	613721	MAGAZINE CASE
40	613738	NOSE ASM.	91	613732	O - RING
41	613693	C - RING	92	613283	SPRING BASE
42	613692	FEED PISTON CAP	93	505914	MODEL LABEL (contact)
43	613251	PIN FEED PISTON		505915	MODEL LABEL (sequential)
44	613695	FEED FINGER SPRING	94	613710	BOLT CAP
45	613253	RETAINER	95	613709	SAFETY COVER
46	613694	FEED FINGER	96	613727	FIXED PIN
47	613698	SPRING	97	613728	FIXED RING
48	501089	RETAINER	98	613726	PROTECTOR
49	613697	FIRST STOPPER FINGER			

**GB: DECLARATION OF CONFORMITY**

We declare that this product is in conformity with the following standards or other normative documents.
ISO12100-1; ISO12100-2; EN 792-13:2000

Following the provision of EEC Directives
98 / 37 / EEC - 07/1993

N: SAMSVARSERKÆRING

Vi erklærer at dette produkt samsvarer med følgende standarder eller normer.
ISO12100-1; ISO12100-2; EN 792-13:2000

Som følger bestemmelser i EU-direktiv
98 / 37 / EEC

D: KONFORMITÄTSEKTLÄRUNG

Wir erklären, dass dieses Produkt mit den folgenden Normen oder normativen Dokumenten übereinstimmt.
ISO12100-1; ISO12100-2; EN 792-13:2000

Gemäß den Bestimmungen der EWG Richtlinien
98 / 37 / EWG

FIN: VAATIMUKSEN MUKAISUUSVAKUUTUS

Vahvistaa, että tämä tuote Paineilmanaulain on seuraavien vaatimusten tai normidokumenttien mukainen.
ISO12100-1; ISO12100-2; EN 792-13:2000

Naiden EEC direktiivien määräysten mukaan
98 / 37 / EEC

NL: KONFORMITEITS VERKLARING

Wij verklaren dat dit produkt conform de volgende standaarden of andere norm stellingen is.
ISO12100-1; ISO12100-2; EN 792-13:2000

Volgens de richtlijnen van de EEC
98 / 37 / EEC

EE: VASTAVUSDEKLARATSIOON:

Käesolevaga kinnitame tööriista vastavust järgnevatele standarditele ja normatiividele:
ISO12100-1; ISO12100-2; EN 792-13:2008

Vastab EEC-direktiivile:
98 / 37 / EEC

F: DÉCLARATION DE CONFORMITÉ

Nous déclarons que ce produit est conforme aux normes ou autres documents normatifs.
ISO12100-1; ISO12100-2; EN 792-13:2000

Conformément aux dispositions des Directives de l'EEC
98 / 37 / CEE

PL: DEKLARACJA ZGODNOŚCI:

Deklarujemy, że ten produkt spełnia następujące standardy lub inne dokumenty normatywne:
ISO12100-1; ISO12100-2; EN 792-13:2007

Spełnia warunki dyrektywy
EEC: 98 / 37 / EEC

E: DECLARACION DE CONFORMIDAD

Nosotros declaramos que este producto está en conformidad con los siguientes estándares u otras normas de documentación.
ISO12100-1; ISO12100-2; EN 792-13:2000

Siguiendo las provisiones de los directivos de EEC
98 / 37 / EEC

CZ: PROHLÁŠENÍ O SHODĚ:

Výrobce prohlašuje že tento výrobek je v souladu s normami či jinými normativními dokumenty: ISO12100-1; ISO12100-2; EN 792-13:2008

Podle pokynů směrnice:
98 / 37 / EEC

P : Declaração de conformidade

Declaramos que este produto está em conformidade com as seguintes normas standard ou outros documentos normativos.
ISO12100-1; ISO12100-2; EN 792-13:2000

Seguindo as directivas EEC
98 / 37 / EEC

H: Termékünk megfelel az

ISO 12100-1, ISO 12100-2, EN 792-13:2000 normáknak, minőségbiztosítási előírásoknak

Termékünk teljesíti a 98 / 37/ EWG előírásait

I: DICHIARAZIONE DE CONFORMITA

Noi dichiariamo che questo prodotto è conforme alle norme o ad altri documenti normativi. ISO12100-1; ISO12100-2; EN 792-13:2000

In conformita alle disposizioni delle Directive CEE
98 / 37 / CEE

SLO: DECLARACIJA SKLADNOSTI

Izjavljamo da je proizvod v skladu z sledečimi standardi ali normativi
ISO12100-1; ISO12100-2; EN 792-13:2008

Sledi ukrepom EEC direktive
98 / 37 / EEC - 07/1993

DK: OVERENSTEMMELSESERKLÆRING

Erklærer herved, at produktet er i overensstemmelse med nedenstående normer eller normative dokumenter.
ISO12100-1; ISO12100-2; EN 792-13:2000

I henhold til bestemmelserne i EU's direktiv
98 / 37 / EEC

HR: DEKLARACIJA SUKLADNOSTI:

ovime potvrđujemo kako je ovaj proizvod sukladan sa sljedećim standardima:
ISO121100-1; ISO12100-2; EN 792-13:2008

Prema EEC direktive:
98 / 37 / EEC

S: KONFORMITETSDEKLARATION

Deklarerar att denna produkt är i konformitet med följande standard eller andra normativa dokument.
ISO12100-1; ISO12100-2; EN 792-13:2000

I enlighet med föreskrifterna i EEC Direktiven
98 / 37 / EEC

ITW Befestigungssysteme Carl-Zeiss-Staße 19 - 30966 Hemmingen

Torsten Weigmann – IU Manager Pneumatic Tools



